



PALMER'S DOLLHOUSE

CONSTRUCTION PLANS AND BASIC ASSEMBLY INSTRUCTIONS



<https://www.facebook.com/StopBelievingStartKnowing>

Dollhouse Technical Drawing and Instructions by Matt Palmer

Questions regarding the interpretation of these directions or general construction of this dollhouse may be directed to Captain Matt Palmer at: mpalmer351@me.com or on  Twitter [@MattP351](https://twitter.com/MattP351). All other questions regarding the presentation and use of this dollhouse for training purposes should be directed to Deputy Chief P.J. Norwood or Lieutenant Sean Gray at: stopbelievingstartknowing@gmail.com or on  Facebook at: <https://www.facebook.com/StopBelievingStartKnowing/info>

FIRE TRAINING DOLLHOUSE

CONSTRUCTION PLANS AND BASIC ASSEMBLY INSTRUCTIONS

Materials Needed:

- 2 sheets of 4' x 8' 7/16" oriented strand board (OSB)
- 1" staples for use with a pneumatic staple gun
- Caulk or construction adhesive (to seal any gaps)

Time Required to Cut and Assemble:

- Depending on your skill level and patience, you should allow 3 to 4 hours to complete this project.
- Although you will ultimately burn this doll house, the skill and accuracy used to assemble this house will ensure a tighter fit and seal between rooms and allow for greater results during the training exercise.

Tools Needed:

- Table saw or worm drive saw (to cut and rip OSB)
- Miter saw
- Jig saw or oscillating multi-tool style saw
- Pneumatic stapler with compressor
- Cordless drill with spade style wood drill bit
- Files or sand paper

WARNING

This drawing is for reference and construction purposes only and NOT designed to serve as a guide on how to conduct training sessions involving any live fire scenario. Any and all training associated with the use of the plans contained herein are done at the user's own risk.

FIRE TRAINING DOLLHOUSE

CONSTRUCTION PLANS AND BASIC ASSEMBLY INSTRUCTIONS

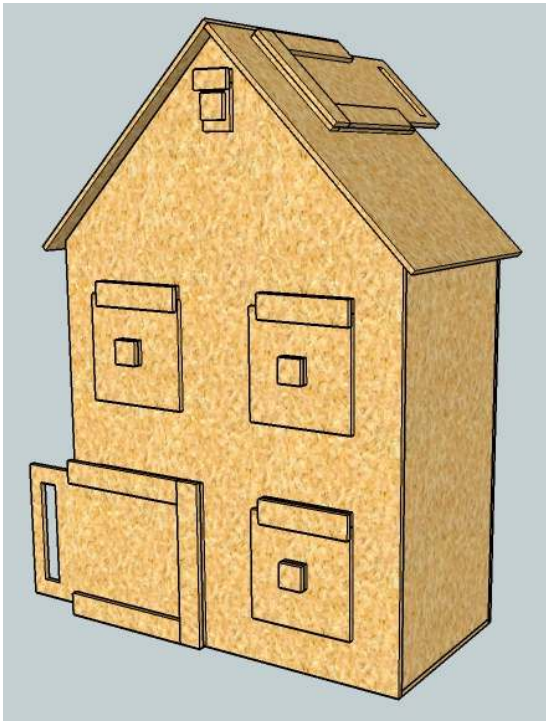

Front View

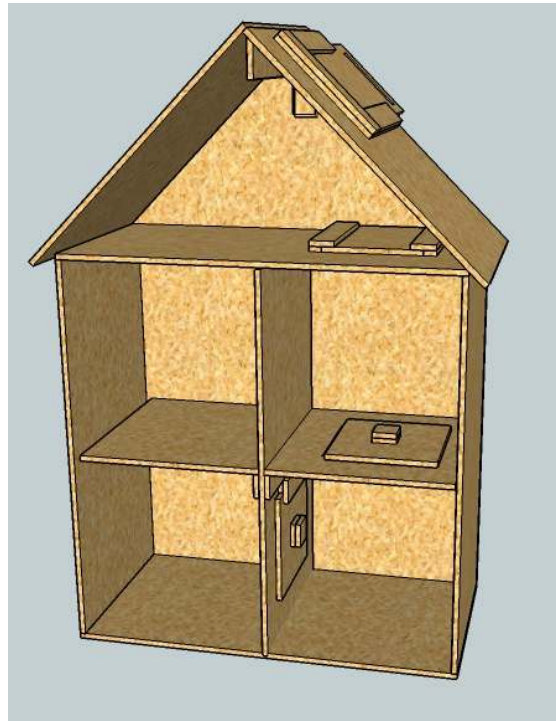

Interior View

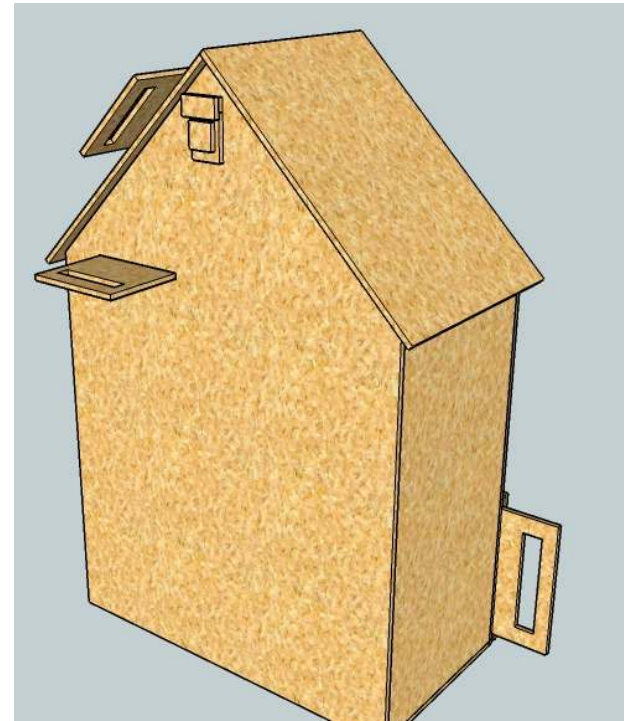

Rear View

CUTTING DIAGRAM – SHEETS OF 7/16” OSB

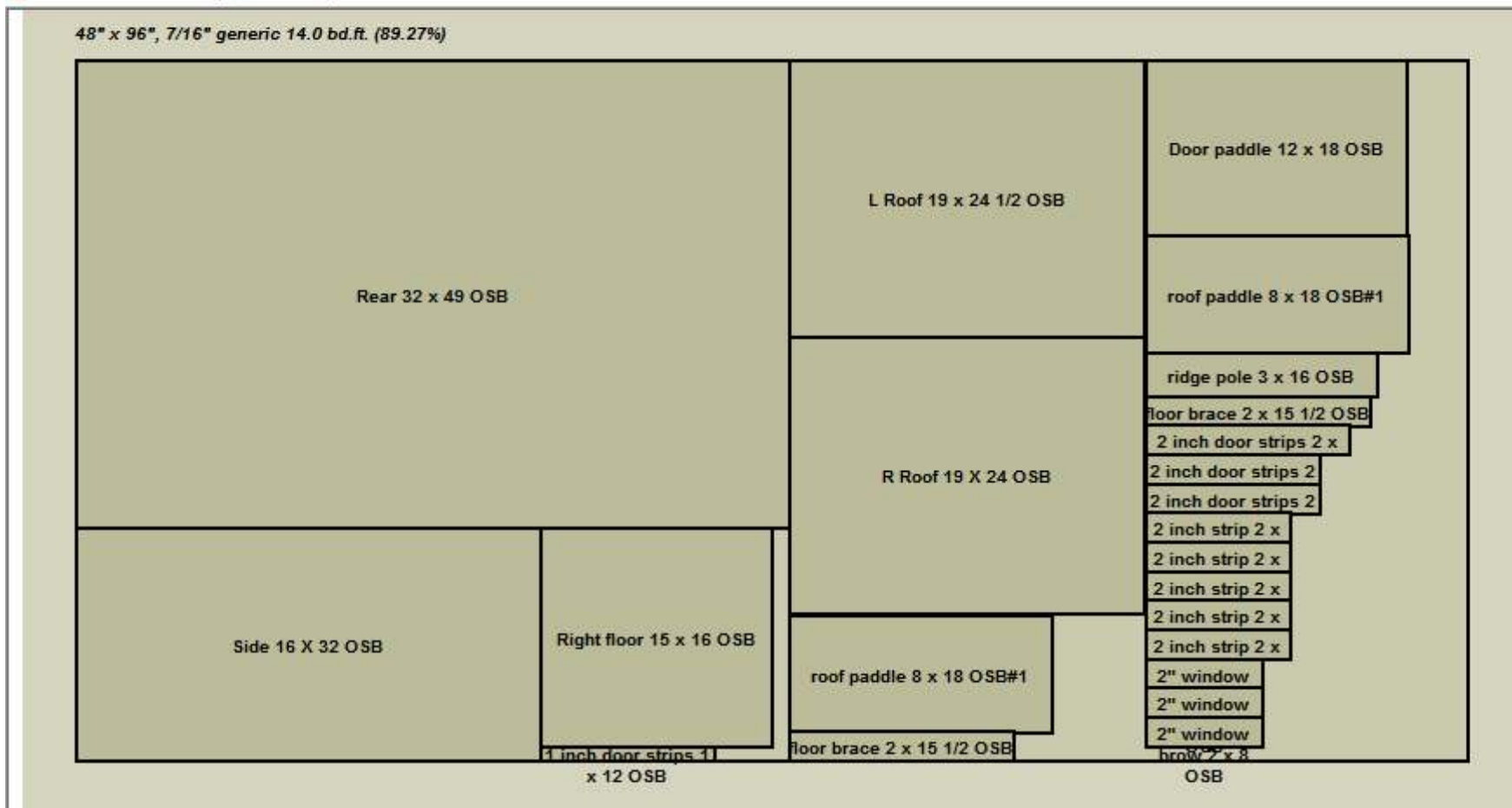

STEP 1 – CUTTING PANELS TO SIZE

SIDE PANEL (NEED 2)

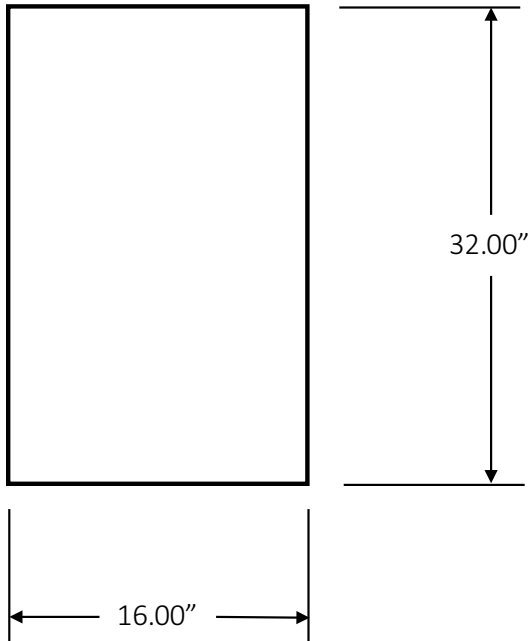

BASE PANEL

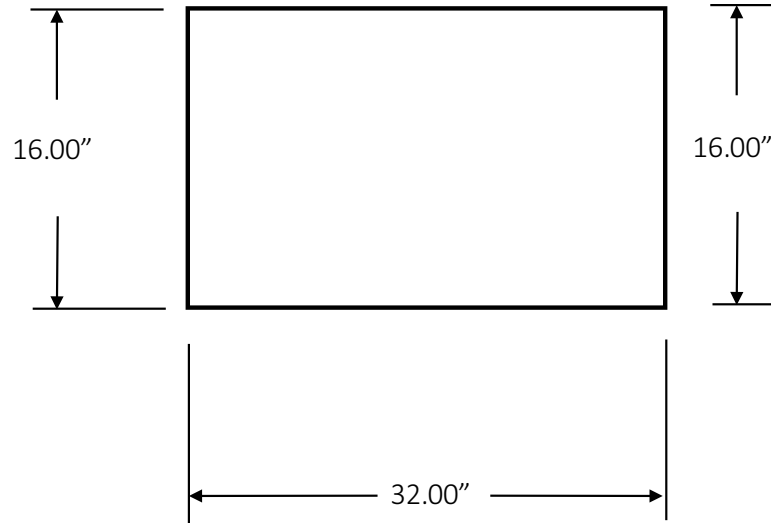

CEILING PANEL

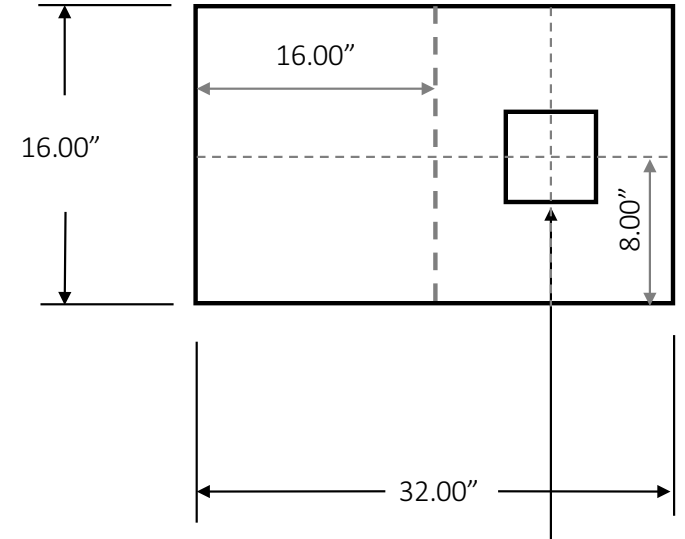

Cut a 6" x 6" square vent hole in the ceiling panel only. The hole should be centered on the right side of the mid-line as shown.

NOTE: NOT TO SCALE

STEP 1 – CUTTING PANELS TO SIZE

CENTER PANEL

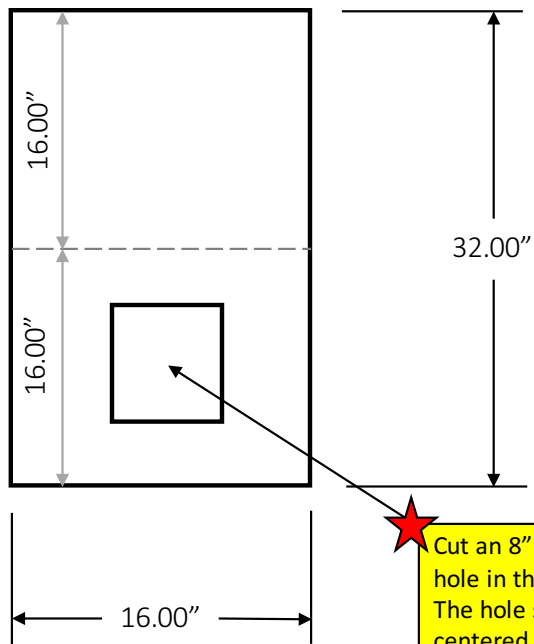

LEFT FLOOR PANEL

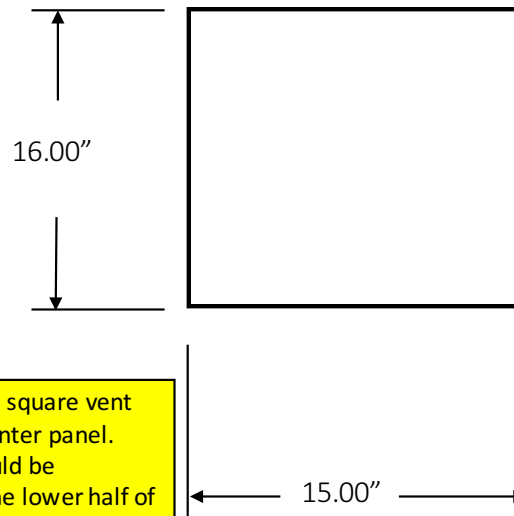

RIGHT FLOOR PANEL

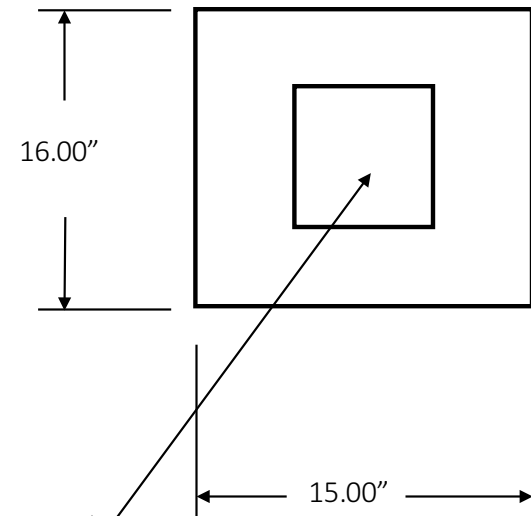

★ Cut an 8" x 8" square vent hole in the center panel. The hole should be centered in the lower half of the center panel. *THIS IS A CRITICAL STEP. DO NOT FORGET TO CUT THE 8" x 8" SQUARE OUT.*

★ Cut an 8" x 8" square vent hole in the right floor panel. The hole should be centered in the floor panel. *THIS IS A CRITICAL STEP. DO NOT FORGET TO CUT THE 8" x 8" SQUARE OUT.*

NOTE: NOT TO SCALE

FRONT PANEL

Cut 3" tall x 2" wide rectangle for gable roof vent. Located midline and just below peak

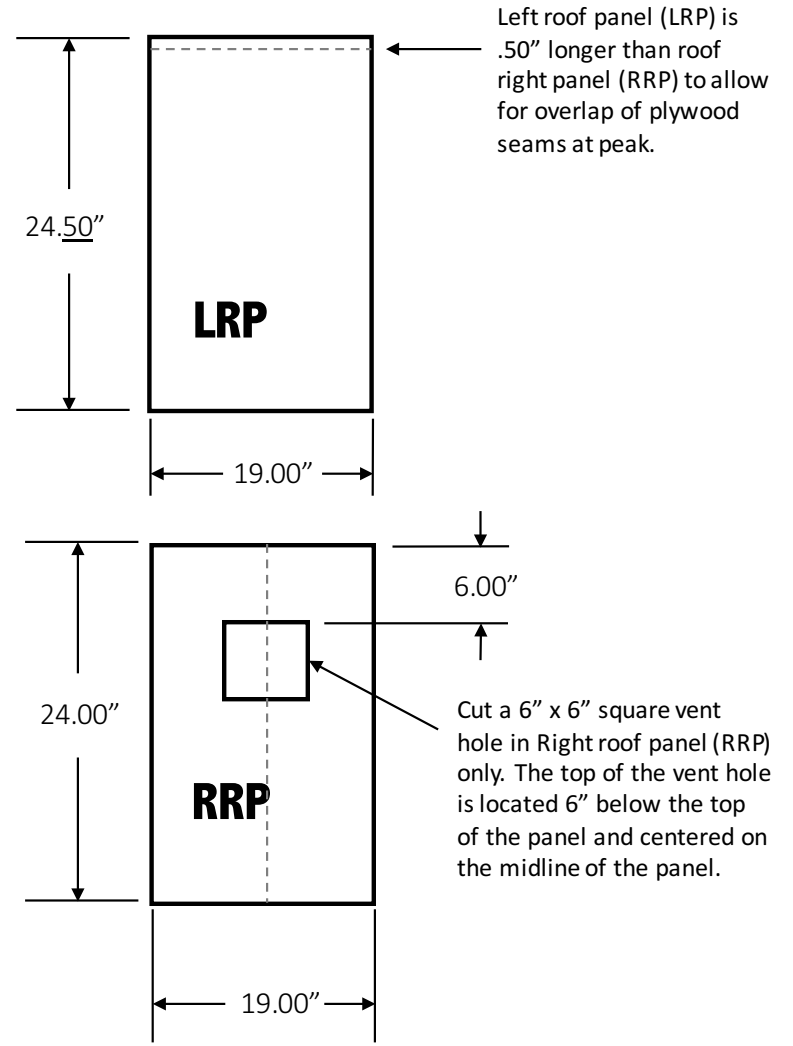
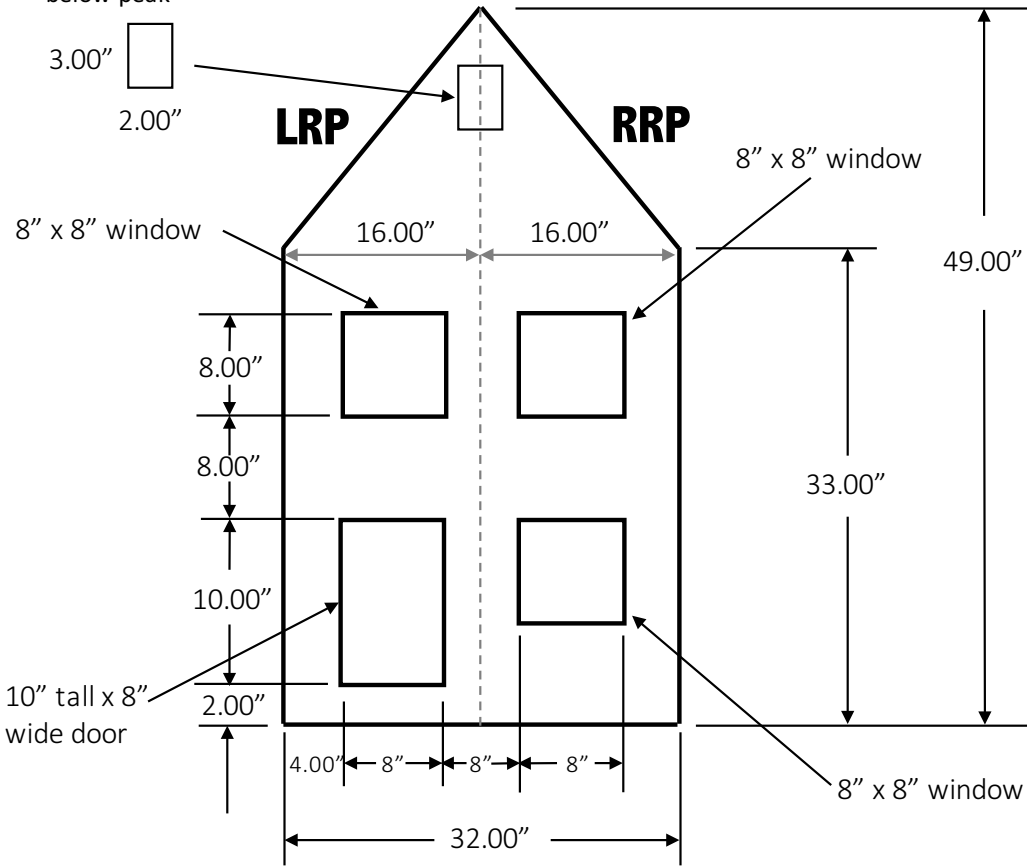
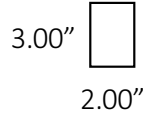

Left roof panel (LRP) is .50" longer than roof right panel (RRP) to allow for overlap of plywood seams at peak.

Cut a 6" x 6" square vent hole in Right roof panel (RRP) only. The top of the vent hole is located 6" below the top of the panel and centered on the midline of the panel.

NOTE: NOT TO SCALE

Cut 3" tall x 2" wide rectangle for gable roof vent. Located midline and just below peak

REAR PANEL

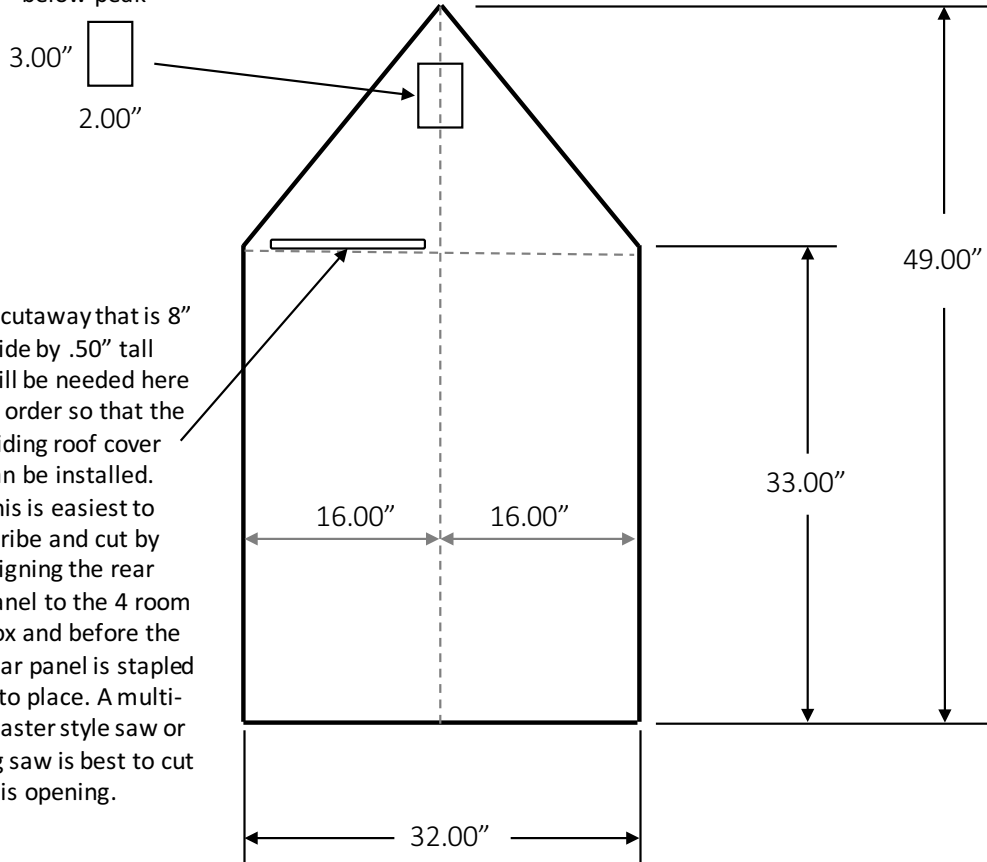

A cutaway that is 8" wide by .50" tall will be needed here in order so that the sliding roof cover can be installed. This is easiest to scribe and cut by aligning the rear panel to the 4 room box and before the rear panel is stapled into place. A multi-master style saw or jig saw is best to cut this opening.

NOTE: NOT TO SCALE

SLIDING ROOF COVER (NEED 2)

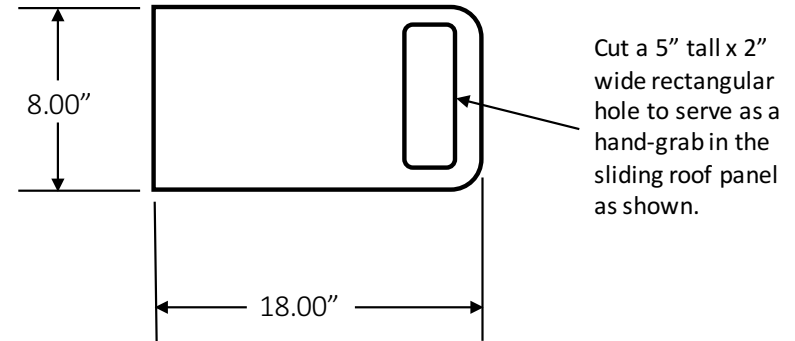

Cut a 5" tall x 2" wide rectangular hole to serve as a hand-grab in the sliding roof panel as shown.

SLIDING FRONT DOOR COVER (NEED 1)

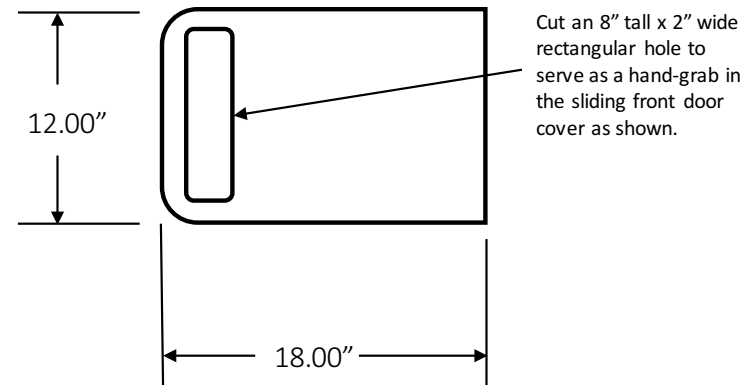

Cut an 8" tall x 2" wide rectangular hole to serve as a hand-grab in the sliding front door cover as shown.

CENTER PANEL

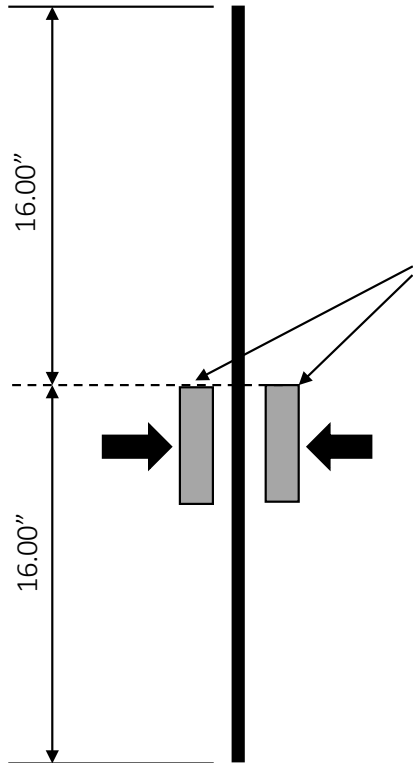

Cut two 2" x 16" strips of OSB using the 7/16" OSB and staple them to each side of the center panel. The upper edge of the strips of OSB should be level along the mid-line (16") of the center panel. The strips will be used to support the left and right side floor panels.

Using the center panel as your guide: Start by stapling the left and right floor panels to the OSB cleats. Next staple the left and right side panels so that the floor panels are level. This should be at the midpoint of the side panels (16"). Once the side panels are secure, staple the base panel and the ceiling panels into place. Be sure that the vent hole in the right panel floor panel and the vent hole on the ceiling panel are inline.

** Caulk or construction adhesive may be necessary to seal seams around wall and ceiling seams of the four rooms. If required, this should be done now and before front and rear walls are installed.

ASSEMBLE THE 4 ROOM BOX

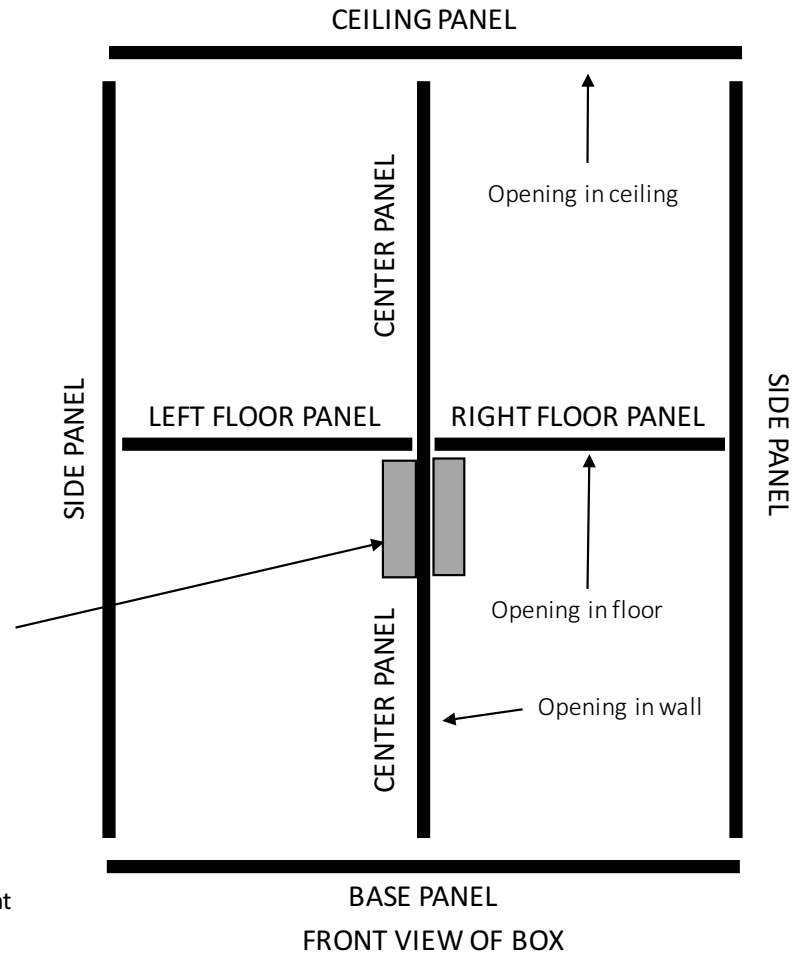

INSTALL THE REAR PANEL

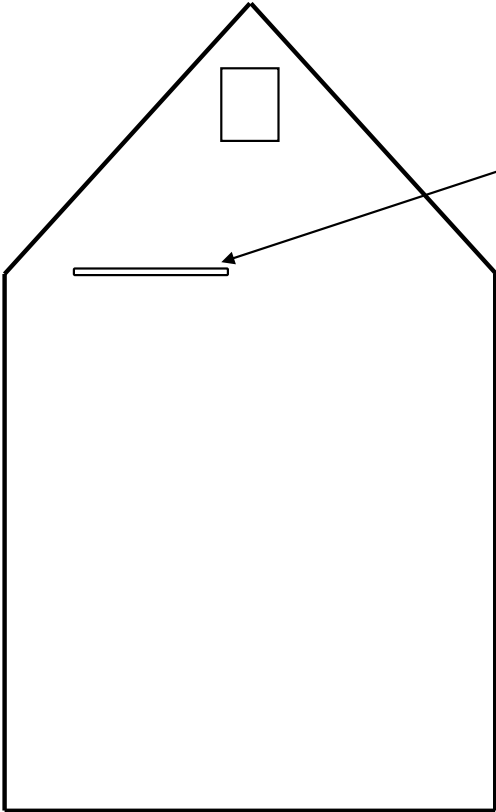

Staple the rear wall to the 4 room box. Be sure that you have scribed and cut the opening for the sliding ceiling vent cover and that it is aligned with the ventilation opening in the ceiling panel.

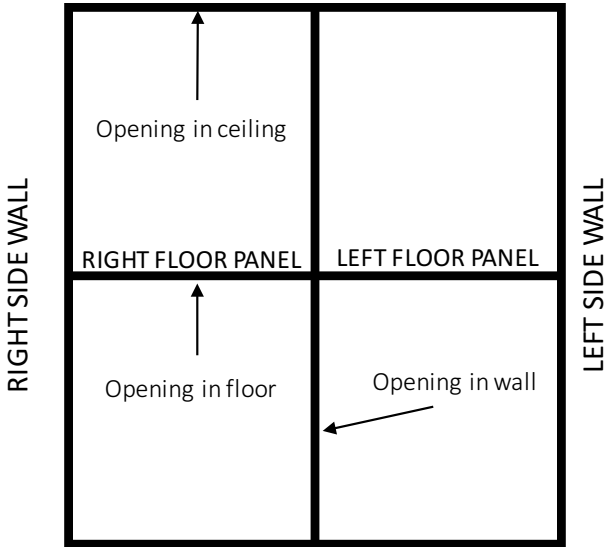

REAR VIEW OF BOX

REAR PANEL

ASSEMBLED 4 ROOM BOX

INSTALL THE FRONT PANEL

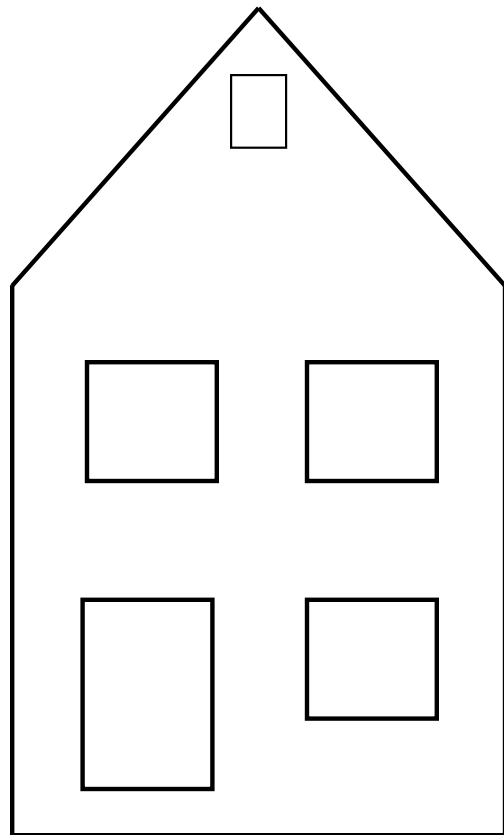

FRONT PANEL

Staple the front wall of the house to the front side of the box. Be sure that the ventilation openings are on the right side of the 4 room box.



ASSEMBLED 4 ROOM BOX

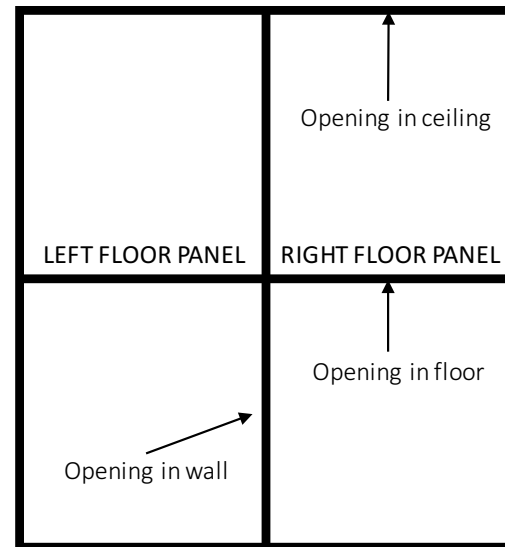

FRONT SIDE OF BOX



At this point, your assembled doll house should look similar to the photo on the left. Before you go any further, you will need to install plywood cleats and create a guide for the sliding ceiling cover. This is best accomplished by cutting strips of 1" and 2" OSB. Be sure to cut extra strips of 1" and 2" OSB as you will be repeating this process for the roof vent slide and the front door vent slides. The ridge pole shown in the picture is optional and not necessary for roof panel installation.

Cut and staple 1" plywood strips around perimeter.

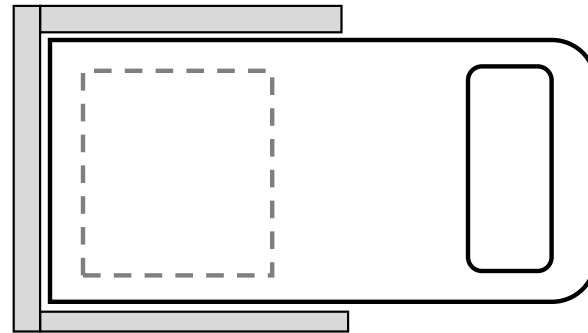

2" plywood strips serve as a cap. Be sure to staple as close to the outer edge as possible and not to staple into the slide!

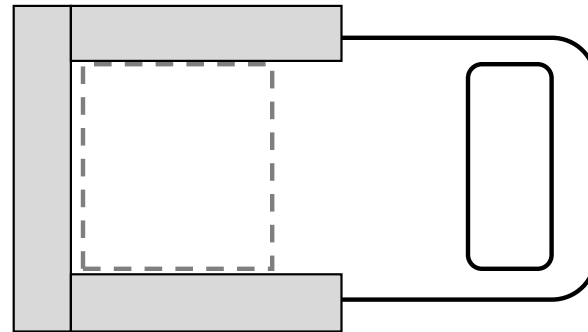



INSTALL THE ROOF PANELS

Once you have the ceiling slide cover operating properly, you are now ready to install the left and right roof panels. Center the roof panels front to back as to allow an equal distance of roof overhang (approx. 1" in front and back). Be sure that the roof vent hole is on the right side of the dollhouse and inline with the ceiling opening below. When the panels are secured and stapled to the gable ends, follow the same steps to create a track for the sliding roof vent cover.

Cut and staple 1" plywood strips around perimeter.

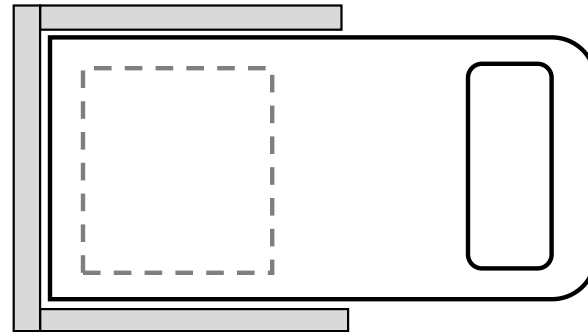

2" plywood strips serve as a cap. Be sure to staple as close to the outer edge as possible and not to staple into the slide!

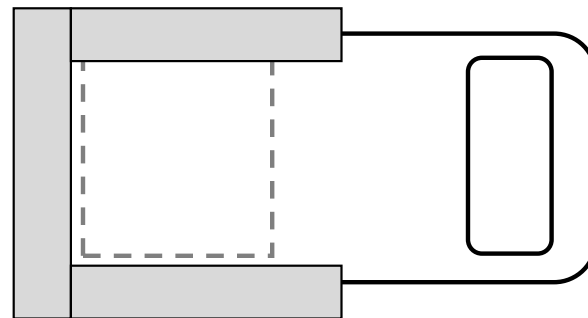

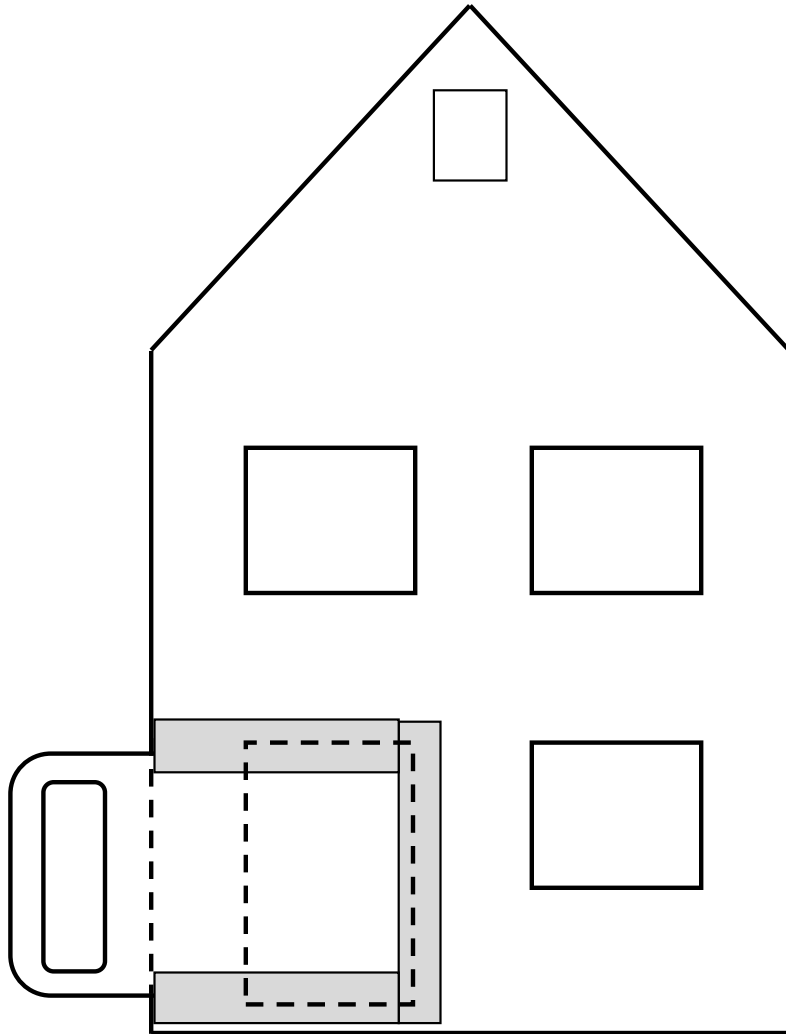

INSTALL THE FRONT DOOR SLIDING COVER

Using additional 1" and 2" OSB strips, follow the same steps for the sliding roof covers to create tracks for the front door sliding cover.



LAST STEP – CREATE WINDOW, WALL, AND FLOOR OPENING COVERS

At this point, you should have plenty of scrap 7/16" plywood around. Before you start throwing it in the scrap pile, you will need to create five (5) covers in order to control smoke and fire gases through interior and exterior openings. Covers are needed for the following openings: windows (3), interior floor/ceiling (1), interior wall openings (1).

****Note:** The portion of this cover that fits into the window or wall opening must be cut and fit as precise as possible or it will not stay seated inside the window opening.

The covers may be made by creating a plywood sandwich using plywood squares, which is stapled together in the manner shown below:

Cover locations (5 Total):

- 3 windows openings in the front.
- Wall opening on first floor between left and right side rooms.
- Floor opening between first and second floors on the right side.

★ **THIS IS A CRITICAL STEP. DO NOT FORGET TO BUILD A TOTAL OF FIVE (5) COVERS. YOU WILL NEED ALL 5 COVERS IN ORDER TO CONTROL THE SPREAD OF SMOKE, GASES, AND FIRE.** ★

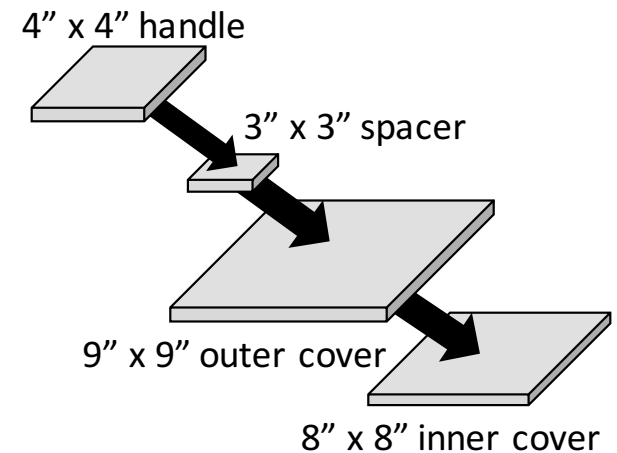



CONGRATULATIONS! THIS COMPLETES YOUR NEW DOLLHOUSE

Some other challenges that you may face:

- If you do not cut the window or door opening covers precisely, they will want to fall forward and not work as designed. If this happens, you can add an OSB guard as shown in the photo to the left to keep the covers from falling out. The guard may be fabricated at your discretion and design.
- Several people have asked about using other types or a wider thickness OSB or conventional types of plywood. The 7/16" OSB that is recommended and will provide ample burn time in order to facilitate the training exercise and has been found to be the best option for this type of training exercise.
- The gable end vents do not need a cover in order to conduct the burn and demonstrate smoke and gas movement. However, if you would like a cover for the gable end, a 2" x 3" plug fabricated in the same fashion as the other covers will work.
- This completes the instructions for the dollhouse. Good luck with your training. Questions or problems with the interpretation of these plans may be directed to Matt Palmer at mpalmer351@me.com . Thank you.

Matt Palmer

Captain, Stamford (CT) Fire Department
Director of Training , Cheshire (CT) Fire Department

17 - END



Modification to the Small Scale Fire Behavior “Palmers Dollhouse”

This modification is to change the opening size and control mechanism located in the center panel. Following these direction will alter the middle panel opening between the lower left and lower right compartment.

We thank Lt. OJ Kolodziej, Lt. Brannon Vernon, FF. Drew Gargus and FF. Luke Ahl from Birmingham Fire and Rescue station 1 for this modification.

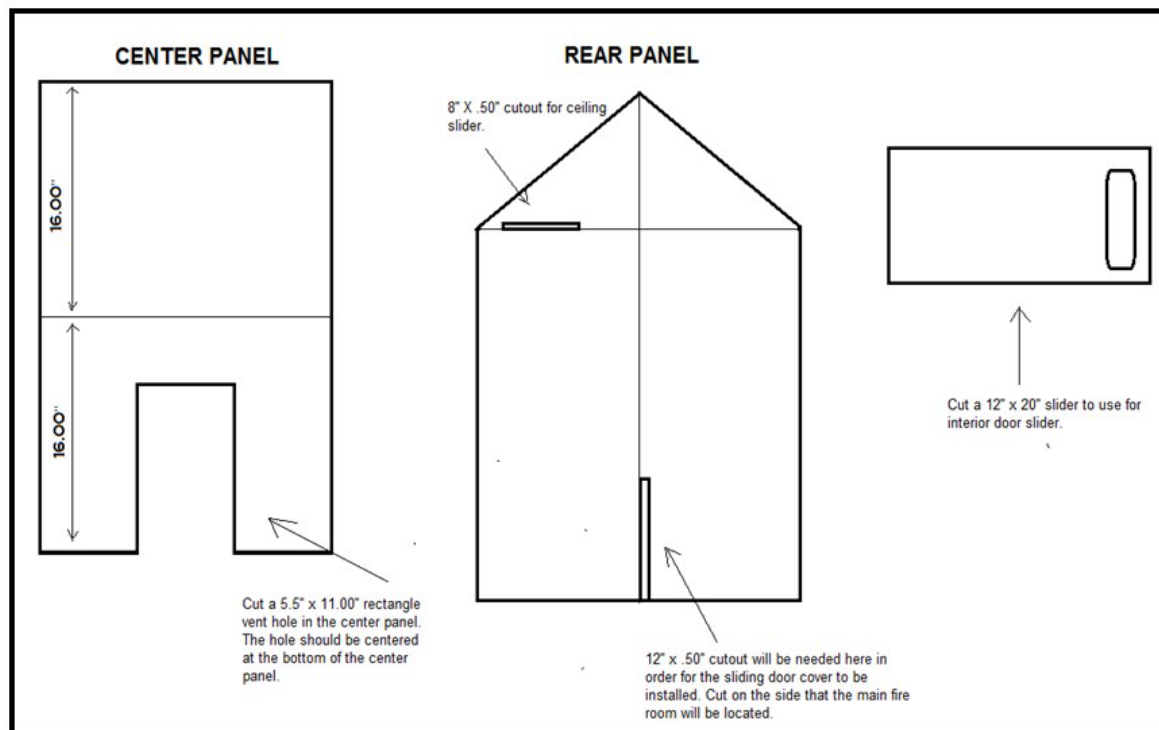
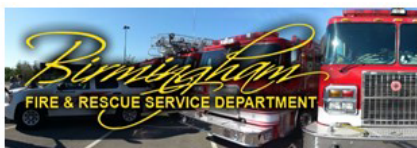

We have Lt. OJ Kolodziej's video of this modification being used located here - <https://youtu.be/7Q2-8bHwvKc>